

### STF700 SmartLine Flange Mounted Level Specification 34-ST-03-103, February 2018



#### Introduction

Part of the SmartLine® family of products, the STF700 is suitable for monitoring, control and data acquisition. STF700 products feature piezoresistive sensor technology combining pressure sensing with on chip temperature compensation capabilities providing high accuracy, stability and performance over a wide range of application pressures and temperatures. The SmartLine family is also fully tested and compliant with Experion® PKS providing the highest level of compatibility assurance and integration capabilities. SmartLine easily meets the most demanding application needs for pressure measurement applications.

#### Best in Class Features:

- Accuracies up to 0.05% standard
- Stability up to 0.02% of URL per year for ten years
- Automatic static pressure & temperature compensation
- Rangeability up to 100:1
- Response times as fast as 90ms
- Multiple local display capabilities
- External zero, span, & configuration capability
- Polarity insensitive electrical connections
- Comprehensive on-board diagnostic capabilities
- Integral Dual Seal design for highest safety based on ANSI/NFPA 70-202 and ANSI/ISA 12.27.0
- World class overpressure protection
- Full compliance to SIL 2/3 requirements.
- Modular design characteristics



Figure 1 – STF700 Flanged Level Transmitters feature field-proven piezoresistive sensor technology

#### Span & Range Limits:

Model	URL “H <sub>2</sub> O (mbar)	LRL “H <sub>2</sub> O (mbar)	Max Span “H <sub>2</sub> O (mbar)	Min Span “H <sub>2</sub> O (mbar)
STF724	400 (1000)	-400 (-1000)	400 (1000)	4.0 (10.0)
STF72F	400 (1000)	-400 (-1000)	400 (1000)	4.0 (10.0)
Model	psi (bar)	psi (bar)	psi (bar)	psi (bar)
STF732	100 (7.0)	-100 (-7.0)	100 (7.0)	1 (0.07)
STF73F	100 (7.0)	-100 (-7.0)	100 (7.0)	1 (0.07)

#### Communications/Output Options:

- 4-20mA dc
- Honeywell Digitally Enhanced (DE)
- HART® (version 7.0)
- FOUNDATION™ Fieldbus

All transmitters are available with the above listed communications protocols.

## Description

The SmartLine family pressure transmitters are designed around a high performance piezo-resistive sensor. This one sensor actually integrates multiple sensors linking process pressure measurement with on-board static pressure (DP Models) and temperature compensation measurements. This level of performance allows the ST 700 to replace most competitive transmitters available today.

## Indication/Display Option

The ST 700 modular design accommodates a basic alphanumeric LCD display.

### Basic Alphanumeric LCD Display Features

- Modular (may be added or removed in the field)
- 0, 90,180, & 270 degree position adjustments
- Configurable (HART only) and standard (Pa, KPa, MPa, KGcm2, Torr, ATM, inH<sub>2</sub>O, mH<sub>2</sub>O, bar, mbar, inH<sub>2</sub>O, inHG, FTH<sub>2</sub>O, mmH<sub>2</sub>O, mm HG, & psi) measurement units
- 2 Lines 16 Characters (4.13H x 1.83W mm)
- Square root output indication ( $\sqrt{\quad}$ )

### Simple LCD Display Features

- Modular (may be added or removed in the field)
- Supports HART protocol variant
- 0, 90,180, & 270 degree position adjustments
- Configurable (HART only) and standard (Pa, KPa, MPa, KGcm2, Torr, ATM, inH<sub>2</sub>O, mH<sub>2</sub>O, bar, mbar, inH<sub>2</sub>O, inHG, FTH<sub>2</sub>O, mmH<sub>2</sub>O, mm HG, & psi) measurement units.
- Supports Flow engineering units
- 2 Lines 6 digits PV (9.95H x 4.20W mm) 8 Characters
- Square root output indication ( $\sqrt{\quad}$ ) and Write protect Indication
- Built in Basic Device Configuration through Internal Buttons – Range/Engineering Unit/Loop Test /Loop Calibration/Zero /Span Setting

## Diagnostics

SmartLine transmitters all offer digitally accessible diagnostics which aid in providing advanced warning of possible failure events minimizing unplanned shutdowns, providing **lower overall operational costs**

## System Integration

- SmartLine communications protocols all meet the most current published standards for HART/DE/Fieldbus.
- Integration with Honeywell's Experion PKS offers the following unique advantages.
  - Tamper reporting
  - FDM Plant Area Views with Health summaries
  - All ST 700 units are Experion tested to provide the highest level of compatibility assurance

## Configuration Tools

### External Three Button Configuration Option

Suitable for all electrical and environmental requirements, SmartLine offers the ability to configure the transmitter and display via three externally accessible buttons when a display option is selected. Zero/span capabilities are also optionally available via these buttons with or without selection of the display option.

### Internal Two Button Configuration Option

The Simple display has two buttons that can be used for Basic configuration such as re ranging, PV Engineering unit setting, Zero/Span settings and Loop testing and calibration functions.

### Hand Held Configuration

SmartLine transmitters feature two-way communication and configuration capability between the operator and the transmitter. This is accomplished via Honeywell's field-rated Multiple Communication Configurator (MCT404). The MCT404 is capable of field configuring DE and HART Devices and can also be ordered for use in intrinsically safe environments. All Honeywell transmitters are designed and tested for compliance with the offered communication protocols and are designed to operate with any properly validated hand held configuration device.

### Personal Computer Configuration

Honeywell's SCT 3000 Configuration Toolkit provides an easy way to configure Digitally Enhanced (DE) instruments using a personal computer as the configuration interface. Field Device Manager (FDM) Software and FDM Express are also available for managing HART & Fieldbus device configurations.

## Modular Design

To help contain maintenance & inventory costs, all ST 700 transmitters are modular in design supporting the user's ability to replace meter bodies, add indicators or change electronic modules without affecting overall performance or approval body certifications. Each meter body is uniquely characterized to provide in-tolerance performance over a wide range of application variations in temperature and pressure and due to the Honeywell advanced interface, electronic modules may be swapped with any electronics module without losing in-tolerance performance characteristics.

### Modular Features

- Meter body replacement
  - Exchange/replace electronics/comms modules\*
  - Add or remove integral indicator\*
  - Add or remove lightning protection (terminal connection)\*
- \* Field replaceable in all electrical environments (including IS) except flameproof without violating agency approvals.

With no performance effects, Honeywell's unique modularity results in **lower inventory needs and lower overall operating costs.**

## Performance Specifications

Reference Accuracy (conformance to +/-3 Sigma)

Table 1

Model	URL	LRL	Min Span	Maximum Turndown Ratio	Stability (%URL/Year for ten years)	Reference Accuracy <sup>1,2</sup> (% Span)
STF724	400 in H <sub>2</sub> O/1000mbar	-400 in H <sub>2</sub> O/-1000mbar	4 in H <sub>2</sub> O/10.0mbar	100:1	0.02%	<b>0.050%</b>
STF72F	400 in H <sub>2</sub> O/1000mbar	-400 in H <sub>2</sub> O/-1000mbar	4 in H <sub>2</sub> O/10.0mbar	100:1	0.02%	<b>0.050%</b>
STF732	100 psi/7.0 bar	-100 psi/-7.0 bar	1 psi/0.07 bar	100:1	0.03%	<b>0.050%</b>
STF73F	100 psi/7.0 bar	-100 psi/-7.0 bar	1 psi/0.07 bar	100:1	0.03%	<b>0.050%</b>

Zero and span may be set anywhere within the listed (URL/LRL) range limits

Accuracy, Span, Temperature and Static Pressure Effect: (Conformance to +/-3 Sigma)

Table 2

Model	URL	Turn down greater than	Accuracy <sup>1,2</sup> (% of Span)			Temperature Effect (% Span/50°F)		Static Line Pressure Effect (% Span/300psi)	
			A	B	C (see URL Units)	D	E	F	G
STF724	400 in H <sub>2</sub> O(1000mbar)	16:1	0.0125	0.0375	25(62.5)	0.260	0.040	0.095	0.010
STF72F	400 in H <sub>2</sub> O (1000mbar)					0.050	0.020	0.025	0.005
Model	URL	Turn down greater than	A	B	C (see URL Units)	D	E	F	G
STF732	100 psi (7.0 bar)	4:1	0.0125	0.0375	25(1.7)	0.075	0.075	0.095	0.010
STF73F	100 psi (7.0 bar)					0.065	0.010	0.026	0.004
			Turn Down Effect $\pm \left[ A + B \left( \frac{C}{\text{Span}} \right) \right]$ % Span			Temp Effect $\pm \left[ D + E \left( \frac{\text{URL}}{\text{Span}} \right) \right]$ % Span per 28°C (50°F)		Static Effect $\pm \left[ F + G \left( \frac{\text{URL}}{\text{Span}} \right) \right]$ % Span per 300 psi	

Total Performance (% of Span):

$$\text{Total Performance} = \pm \sqrt{(\text{Accuracy})^2 + (\text{Temp Effect})^2 + (\text{Static Line Pressure Effect})^2}$$

Total Performance Examples: (5:1 Turndown, up to 50 °F shift & up to 300 psi Static Pressure)

STF724 @ 80" H<sub>2</sub>O: 0.485% of span

STF732 @ 20 psi: 0.475 % of span

STF72F @ 80" H<sub>2</sub>O: 0.166% of span

STF73F @ 20 psi: 0.137% of span

Typical Calibration Frequency:

Calibration verification is recommended every two (2) years

Notes:

- Terminal Based Accuracy – Includes effects of linearity, hysteresis and repeatability. Analog output adds 0.005% of span
- For zero based spans and reference conditions of 25°C, 0 psig static pressure, 10 to 55% RH.

## Operating Conditions – All Models

Parameter	Reference Condition		Rated Condition		Operative Limits		Transportation and Storage	
	°C	°F	°C	°F	°C	°F	°C	°F
<b>Ambient Temperature</b>	25±1	77±2	-40 to 85	-40 to 185	-40 to 85	-40 to 185	-55 to 120	-67 to 248
<b>Meter Body Temperature</b>	25±1	77±2	-40 to 110 <sup>1</sup>	-40 to 230 <sup>1</sup>	-40 to 125	-40 to 257	-55 to 120	-67 to 248
<b>Process Interface Temp.</b> STF724, STF732 only	25±1	77±2	-40 to 110 <sup>1</sup>	-40 to 230 <sup>1</sup>	-40 to 175 <sup>2</sup>	-40 to 350 <sup>2</sup>	-55 to 125	-67 to 257
<b>Humidity</b> %RH	10 to 55		0 to 100		0 to 100		0 to 100	
<b>Minimum Pressure</b> mmHg absolute inH <sub>2</sub> O absolute	atmospheric atmospheric		25 13		2 (short term <sup>3</sup> ) 1 (short term <sup>3</sup> )			
<b>Supply Voltage</b> <b>Load Resistance</b>	10.8 to 42.4 Vdc at terminals 0 to 1,440 ohms (as shown in <a href="#">Figure 2</a> )							

<sup>1</sup> Silicone 704 minimum temperature rating is 0°C (32°F). NEOBEE® M-20 minimum temperature rating is -15°C (5°F)

NEOBEE® is a registered trademark of Stepan Company

<sup>2</sup> For CTFE fill fluid, the maximum temperature rating is 150°C (300°F)

<sup>3</sup> Short term equals 2 hours at 70°C (158 °F)

### Maximum Allowable Working Pressure (MAWP)<sup>5, 6</sup>

(ST 800 products are rated to Maximum Allowable Working Pressure. MAWP depends on Approval Agency and transmitter materials of construction.)

STF 724 & STF 732	Flange Material	Ambient Temperature -29 to 38°C [-20 to 100°F]	Max Meterbody Temperature 125°C [257°F]	Process Interface Temperature 175°C [350°F]
ANSI Class 150 <b>psi [bar]</b>	Carbon Steel	285 [19.6]	245 [16.9]	215 [14.8]
	304 S.S.	275 [19.0]	218 [15.0]	198 [13.7]
	316 S.S.	275 [19.0]	225 [15.5]	205 [14.1]
ANSI Class 300 <b>psi [bar]</b>	Carbon Steel	740 [51.0]	668 [46.0]	645 [44.5]
	304 S.S.	720 [49.6]	570 [39.3]	518 [35.7]
	316 S.S.	720 [49.6]	590 [40.7]	538 [37.1]
DN PN40 <b>psi [bar]</b>	Carbon Steel	580 [40.0] <sup>4</sup>	574 [39.6]	559 [38.5]
	304 S.S.	534 [36.8] <sup>4</sup>	419 [28.9]	385 [26.5]
	316 S.S.	534 [36.8] <sup>4</sup>	434 [29.9]	399 [27.5]
<b>STF72F&amp; STF73F</b> ANSI Class 150 psi [bar]	316L Stainless Steel	230 [15.9]	185 [12.8]	No rating at this temp

<sup>4</sup> Ambient Temperature for DN PN40 is -10 to 50°C [14 to 122 F]

<sup>5</sup> MAWP applies for temperature range -40 to 125°C. However, Static Pressure Limit is de-rated to 3,000 psi from -26°C to -40°C.

Use of graphite o-rings de-rates transmitter to 3,625 psi. Use of adaptor with graphite o-rings de-rates transmitter to 3,000 psi.

<sup>6</sup> Consult factory for MAWP of ST 800 transmitters with CSA approval.



## Materials Specifications (see model selection guide for availability/restrictions with various models)

Parameter	Description
Barrier Diaphragms Material	316L SS, Hastelloy® C-276 <sup>2</sup> , Monel® 400 <sup>**3</sup>
Process Head Material	316 SS <sup>4</sup> , Carbon Steel (Zinc-plated) <sup>5</sup> , Hastelloy C-276 <sup>*6</sup> , Monel 400 <sup>**7</sup>
Vent/Drain Valves & Plugs <sup>1</sup>	316 SS <sup>4</sup> , Hastelloy C-276 <sup>2</sup> , Monel 400 <sup>7</sup>
Gasket Ring Material (Wetted)	316/316L SS, Hastelloy® C-276 <sup>*2</sup> , Monel®400 <sup>**3</sup>
Extension Tube Material	316 SS <sup>4</sup>
Head Gaskets	Glass-filled PTFE standard. Viton® and graphite are optional.
Meter Body Bolting	Carbon Steel (Zinc plated) standard. Options include 316 SS, NACE A286 SS bolts, Monel K500, Super Duplex and B7M.
Optional Adapter Flange and Bolts	Adapter Flange materials include 316 SS <sup>4</sup> , Hastelloy C-276 <sup>6</sup> and Monel 400 <sup>7</sup> . Bolt material for flanges is dependent on process head bolts material chosen. Standard adaptor seal material is glass-filled PTFE. Viton and graphite are optional.
Mounting Flange STF724, STF732 STF72F, STF73F	<b>Flush or Extended Diaphragm:</b> Zinc Chromate plated Carbon Steel <sup>5</sup> , 304 SS, or 316 SS <sup>4</sup> . 316L SS (NOTE: Mounting Flange is process wetted.)
Fill Fluid	Silicone 200, CTFE, NEOBEE M-20 or Silicone 704
Electronic Housing	Pure Polyester Powder Coated Low Copper (<0.4%)-Aluminum. Meets NEMA 4X, IP66, & P67. All stainless steel housing is optional.
Mounting	See <a href="#">Figure 3</a> for typical flange mounting arrangement.
Process Connections  All Models STF724, STF732  STF72F, STF73F	<b>Process Head:</b> 1/4-inch NPT; 1/2-inch NPT with adapter and DIN, standard options. <b>Flange:</b> 2, 3 or 4-inch Class 150 or 300 ANSI; DN50-PN40, DN80-PN40 or DN100-PN40 DIN flange. <b>Extended Diaphragm:</b> 2, 4, or 6 inches (50, 101, 152 mm) long. 2 or 3-inch, Class 150 ANSI flange.
Wiring	Accepts up to 16 AWG (1.5 mm diameter).
Dimensions	See <a href="#">Figure 4</a> , <a href="#">Figure 5</a> & <a href="#">Figure 6</a>
Net Weight	STF72F, STF73F: 14-19 pounds (6.4 - 8.7Kg) with Aluminum Housing STF724, STF732: 18-32 pounds (8.2 - 14.5Kg) with Aluminum Housing

<sup>1</sup> Vent/Drains are sealed with Teflon®

<sup>2</sup> Hastelloy C-276 or UNS N10276

<sup>3</sup> Monel 400 or UNS N04400

<sup>4</sup> Supplied as 316 SS or as Grade CF8M, the casting equivalent of 316 SS.

<sup>5</sup> Carbon Steel heads are zinc-plated and not recommended for water service due to hydrogen migration. For that service, use 316 stainless steel wetted Process Heads.

<sup>6</sup> Hastelloy C-276 or UNS N10276. Supplied as indicated or as Grade CW12MW, the casting equivalent of Hastelloy C-276

<sup>7</sup> Monel 400 or UNS N04400. Supplied as indicated or as Grade M30C, the casting equivalent of Monel 400

\* Flush design only.

\*\*Flush or pseudo flange design.

## Communications Protocols & Diagnostics

### HART Protocol

#### Version:

HART 7

#### Power Supply

Voltage: 10.8 to 42.4Vdc at terminals

Load: Maximum 1440 ohms See [Figure 2](#).

Minimum Load: 0 ohms. (For handheld communications a minimum load of 250 ohms is required)

### Foundation Fieldbus (FF)

#### Power Supply Requirements

Voltage: 9.0 to 32.0Vdc at terminals

Steady State Current: 17.6mAdc

Software Download Current: 27.4mAdc

#### Available Function Blocks

Block Type	Qty	Execution Time
Resource	1	n/a
Transducer	1	n/a
Diagnostic	1	n/a
Analog Input	1*	30 ms
PID w/Autotune	1	45 ms
Integrator	1	30 ms
Signal Char (SC)	1	30 ms
LCD Display	1	n/a
Flow Block	1	30 ms
Input Selector	1	30 ms
Arithmetic	1	30 ms

\* AI block may have two (2) additional instantiations.

All available function blocks adhere to FOUNDATION Fieldbus standards. PID blocks support ideal & robust PID algorithms with full implementation of Auto-tuning.

#### Link Active Scheduler

Transmitters can perform as a backup Link Active Scheduler and take over when the host is disconnected. Acting as a LAS, the device ensures scheduled data transfers typically used for the regular, cyclic transfer of control loop data between devices on the Fieldbus.

#### Number of Devices/Segment

Entity IS model: 6 devices/segment

#### Schedule Entries

18 maximum schedule entries

#### Number of VCR's: 24 max

**Compliance Testing:** Tested according to ITK 6.0.1

### Software Download

Utilizes Class-3 of the Common Software Download procedure as per FF-883 which allows the field devices of any manufacturer to receive software upgrades from any host.

### Honeywell Digitally Enhanced (DE)

DE is a Honeywell proprietary protocol which provides digital communications between Honeywell DE enabled field devices and Hosts.

#### Power Supply

Voltage: 10.8 to 42.4Vdc at terminals

Load: Maximum 1440 ohms See [Figure 2](#).

### Standard Diagnostics

ST 700 top level diagnostics are reported as either critical or non-critical and readable via the DD/DTM tools or integral display as shown below.

#### Critical Diagnostics

HART DD/DTM Tools	Basic Display	Simple Display
Electronic Module DAC Failure	Electronics module fault	Fault Comm EI
Meter Body NVM Corrupt	Meter Body fault	Fault Mtrbody
Config. Data Corrupt	Electronics module fault	Fault Comm EI
Electronic Module Diag Failure	Electronics module fault	Fault Comm EI
Meter Body Critical Failure	Meter Body fault	Fault Mtrbody
Sensor Comms Timeout	Meter Body Comm fault	Fault Mbd Com

#### Non-Critical Diagnostics

HART DD/DTM Tools
Display Failure
Electronic Module Comm Failure
Meter Body Excess Correct
Sensor Over Temperature
Fixed Current Mode
PV Out of Range
No Factory Calibration
No DAC Compensation
LRV Set Error – Zero Config. Button
URV Set Error – Zero Config. Button
AO Out of Range
Loop Current Noise
Meter Body Unreliable Comm
Tamper Alarm,
No DAC Calibration
Sensor Supply Voltage Low

Refer to ST 700 manuals for additional level diagnostic information.

## Approval Certifications:

AGENCY	TYPE OF PROTECTION	COMM. OPTION	FIELD PARAMETERS	AMBIENT TEMP (Ta)
FM Approvals™	<b>Explosionproof:</b> Class I, Division 1, Groups A, B, C, D; <b>Dust Ignition Proof:</b> Class II, III, Division 1, Groups E, F, G; T4  Class I, Zone 0/1, AEx d IIC Ga/Gb Class II, Zone 21, AEx tb IIIC Db T 95°C	All	Note 1	T5: -50 °C to 85°C T6: -50 °C to 65°C
	<b>Intrinsically Safe:</b> Class I, II, III, Division 1, Groups A, B, C, D, E, F, G; T4  Class I, Zone 0, AEx ia IIC Ga T4  FISCO Field Device (Only for FF Option) Ex ia IIC T4	4-20 mA / DE/ HART	Note 2a	-50 °C to 70°C
	<b>Nonincendive:</b> Class I, Division 2, Groups A, B, C, D locations,  Class I, Zone 2, AEx nA IIC Gc T4	4-20 mA / DE/ HART/ Foundation Fieldbus	Note 1	-50 °C to 85°C
	<b>Enclosure:</b> Type 4X/ IP66/ IP67	All	All	-
	<b>Explosion Proof:</b> Class I, Division 1, Groups A, B, C, D; <b>Dust Ignition Proof:</b> Class II, III, Division 1, Groups E, F, G;  Ex d IIC Ga Ex tb IIIC Db T 95°C	All	Note 1	T5: -50 °C to 85°C T6: -50 °C to 65°C
	<b>Intrinsically Safe:</b> Class I, II, III, Division 1, Groups A, B, C, D, E, F, G; T4  Ex ia IIC Ga T4  FISCO Field Device (Only for FF Option) Ex ia IIC T4	4-20 mA / DE/ HART	Note 2a	-50 °C to 70°C
Canadian Standards Association (CSA)	<b>Nonincendive:</b> Class I, Division 2, Groups A, B, C, D; T4  Ex nA IIC Gc T4	4-20 mA / DE/ HART/ Foundation Fieldbus	Note 1	-50 °C to 85°C
	<b>Enclosure:</b> Type 4X/ IP66/ IP67	All	All	-



## Approval Certifications: (Continued)

<b>ATEX</b>	<b>Flameproof:</b> II 1/2 G Ex d IIC Ga/Gb II 2 D Ex tb IIIC Db T 95°C	All	Note 1	T5: -50 °C to 85°C T6: -50 °C to 65°C
	<b>Intrinsically Safe:</b> II 1 G Ex ia IIC Ga T4	4-20 mA / DE/ HART	Note 2a	-50 °C to 70°C
	FISCO Field Device (Only for FF Option) Ex ia IIC T4	Foundation Fieldbus	Note 2b	-50 °C to 70°C
	<b>Nonincendive:</b> II 3 G Ex nA IIC Gc T4	4-20 mA / DE/ HART/ Foundation Fieldbus	Note 1	-50 °C to 85°C
	<b>Enclosure:</b> IP66/ IP67	All	All	-
<b>IECEX (World)</b>	<b>Flameproof :</b> Ex d IIC Ga/Gb T4 Ex tb IIIC Db T 95°C	All	Note 1	T5: -50 °C to 85°C T6: -50 °C to 65°C
	<b>Intrinsically Safe:</b> Ex ia IIC Ga T4	4-20 mA / DE/ HART	Note 2a	-50 °C to 70°C
	FISCO Field Device (Only for FF Option) Ex ia IIC T4	Foundation Fieldbus	Note 2b	-50 °C to 70°C
	<b>Nonincendive:</b> Ex nA IIC Gc T4	4-20 mA / DE/ HART/ Foundation Fieldbus	Note 1	-50 °C to 85°C
	<b>Enclosure:</b> IP66/ IP67	All	All	-
<b>SAEx (South Africa)</b>	<b>Flameproof :</b> Ex d IIC Ga/Gb T4 Ex tb IIIC Db T 95°C	All	Note 1	-50 °C to 85°C
	<b>Intrinsically Safe:</b> Ex ia IIC Ga T4	4-20 mA / DE/ HART	Note 2a	-50 °C to 70°C
	FISCO Field Device (Only for FF Option) Ex ia IIC T4	Foundation Fieldbus	Note 2b	-50 °C to 70°C
	<b>Nonincendive:</b> Ex nA IIC Gc T4	4-20 mA / DE/ HART/ Foundation Fieldbus	Note 1	-50 °C to 85°C
	<b>Enclosure:</b> IP66/ IP67	All	All	-
<b>INMETRO (Brazil)</b>	<b>Flameproof:</b> Ex d IIC Ga/ Gb T4 Ex tb IIIC Db T 95°C	All	Note 1	-50 °C to 85°C
	<b>Intrinsically Safe:</b> Ex ia IIC Ga T4	4-20 mA / DE/ HART	Note 2a	-50 °C to 70°C
	FISCO Field Device (Only for FF Option) Ex ia IIC T4	Foundation Fieldbus	Note 2b	-50 °C to 70°C
	<b>Nonincendive:</b> Ex nA IIC Gc T4	4-20 mA / DE/ HART/ Foundation Fieldbus	Note 1	-50 °C to 85°C
	<b>Enclosure :</b> IP 66/67	All	All	-

**Approval Certifications: (Continued)**

<b>NEPSI (China)</b>	<b>Flameproof:</b> Ex d IIC Ga/Gb T4 Ex tb IIIC Db T 85°C	All	Note 1	-50 °C to 85°C
	<b>Intrinsically Safe:</b> Ex ia IIC Ga T4	4-20 mA / DE/ HART	Note 2a	-50 °C to 70°C
	FISCO Field Device (Only for FF Option) Ex ia IIC T4	Foundation Fieldbus	Note 2b	-50 °C to 70°C
	<b>Nonincendive:</b> Ex nA IIC Gc T4	4-20 mA / DE/ HART/ Foundation Fieldbus	Note 1	-50 °C to 85°C
	<b>Enclosure :</b> IP 66/67	All	All	-
<b>GOST</b>	<b>Flameproof:</b> 1 Ex d IIC Ga/Gb T4 Ex tb IIIC Db T 85°C	All	Note 1	-50 °C to 85°C
	<b>Intrinsically Safe:</b> 0 Ex ia IIC Ga T4	4-20 mA / DE/ HART	Note 2a	-50 °C to 70°C
	FISCO Field Device (Only for FF Option) Ex ia IIC T4	Foundation Fieldbus	Note 2b	-50 °C to 70°C
	<b>Enclosure :</b> IP 66/67	All	All	

**Notes:**

## 1. Operating Parameters:

Voltage= 11 to 42 V DC      Current= 4-20 mA Normal  
= 10 to 30 V (FF)              = 30 mA (FF)

## 2. Intrinsically Safe Entity Parameters

## a. Analog/ DE/ HART Entity Values:

V<sub>max</sub>= U<sub>i</sub> = 30V      I<sub>max</sub>= I<sub>i</sub>= 105mA      C<sub>i</sub> = 4.2nF      L<sub>i</sub> =984 uH      P<sub>i</sub> =0.9W

Transmitter with Terminal Block Revision E or Later

V<sub>max</sub>= U<sub>i</sub> = 30V      I<sub>max</sub>= I<sub>i</sub>= 225mA      C<sub>i</sub> = 4.2nF      L<sub>i</sub> = 0      P<sub>i</sub> =0.9W

Note : Transmitter with Terminal Block Revision E or later

The revision is on the label that is on the module. There will be two lines of text on the label:

- First is the Module Part #: 50049839-001 or 50049839-002
- Second line has the supplier information, along with the REVISION:  
XXXXXXX-EXXXX, THE "X" is production related, THE POSITION of the "E" IS THE REVISION.

## b. Foundation Fieldbus- Entity Values

V<sub>max</sub>= U<sub>i</sub> = 30V      I<sub>max</sub>= I<sub>i</sub>= 180mA      C<sub>i</sub> = 0nF      L<sub>i</sub> = 984 uH      P<sub>i</sub> =1W

Transmitter with Terminal Block Revision F or Later

V<sub>max</sub>= U<sub>i</sub> = 30V      I<sub>max</sub>= I<sub>i</sub>= 225mA      C<sub>i</sub> =0nF      L<sub>i</sub> = 0      P<sub>i</sub> =1 W

FISCO Field Device      I<sub>max</sub>= I<sub>i</sub>= 380 mA      C<sub>i</sub> = 0nF      L<sub>i</sub> = 0      P<sub>i</sub> =5.32 W

V<sub>max</sub>= U<sub>i</sub> = 17.5V

Note : Transmitter with Terminal Block Revision F or later

The revision is on the label that is on the module. There will be two lines of text on the label:

- First is the Module Part #: 50049839-003 or 50049839-004
- Second line has the supplier information, along with the REVISION:  
XXXXXXX-EXXXX, THE "X" is production related, THE POSITION of the "E" IS THE REVISION.

### Approval Certifications: (Continued)

<b>Marine Certificates</b>	<p>This certificate defines the certifications covered for the ST 800 Pressure Transmitter family of products, including the SMV 800 Smart Multivariable Transmitter. It represents the compilation of the five certificates Honeywell currently has covering the certification of these products into marine applications.</p> <p>For SmartLine Pressure Transmitter and SMV800 Smart Multivariable Transmitter</p>
	<p><b>American Bureau of Shipping (ABS)</b> - 2009 Steel Vessel Rules 1-1-4/3.7, 4-6-2/5.15, 4-8-3/13 &amp; 13.5, 4-8-4/27.5.1, 4-9-7/13. Certificate number: 04-HS417416-PDA</p>
	<p><b>Bureau Veritas (BV)</b> - Product Code: 389:1H. Certificate number: 12660/B0 BV</p>
	<p><b>Det Norske Veritas (DNV)</b> - Location Classes: Temperature D, Humidity B, Vibration A, EMC B, Enclosure C. For salt spray exposure; enclosure of 316 SST or 2-part epoxy protection with 316 SST bolts to be applied. Certificate number: A-11476</p>
	<p><b>Korean Register of Shipping (KR)</b> - Certificate number: LOX17743-AE001</p>
	<p><b>Lloyd's Register (LR)</b> - Certificate number: 02/60001(E1) &amp; (E2)</p>
<b>SIL 2/3 Certification</b>	<p>IEC 61508 SIL 2 for non-redundant use and SIL 3 for redundant use according to EXIDA and TÜV Nord Sys Tec GmbH &amp; Co. KG under the following standards: IEC61508-1: 2010; IEC 61508-2: 2010; IEC61508-3: 2010.</p>

### Other Certification Options

#### Materials

- NACE MRO175, MRO103, ISO15156

### Dimensional Drawings

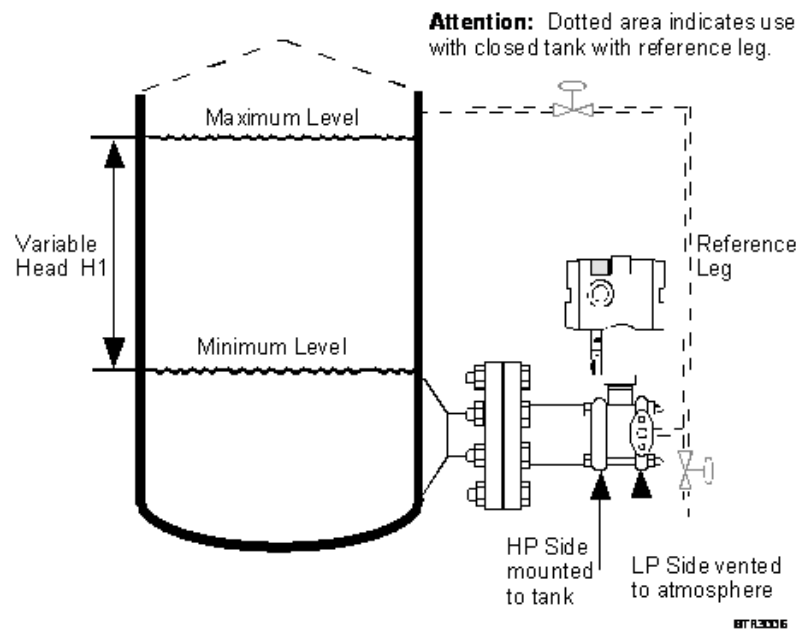

Figure 3 – Typical mounting for flange mounted level transmitter

**Dimensional Drawings (con't)**

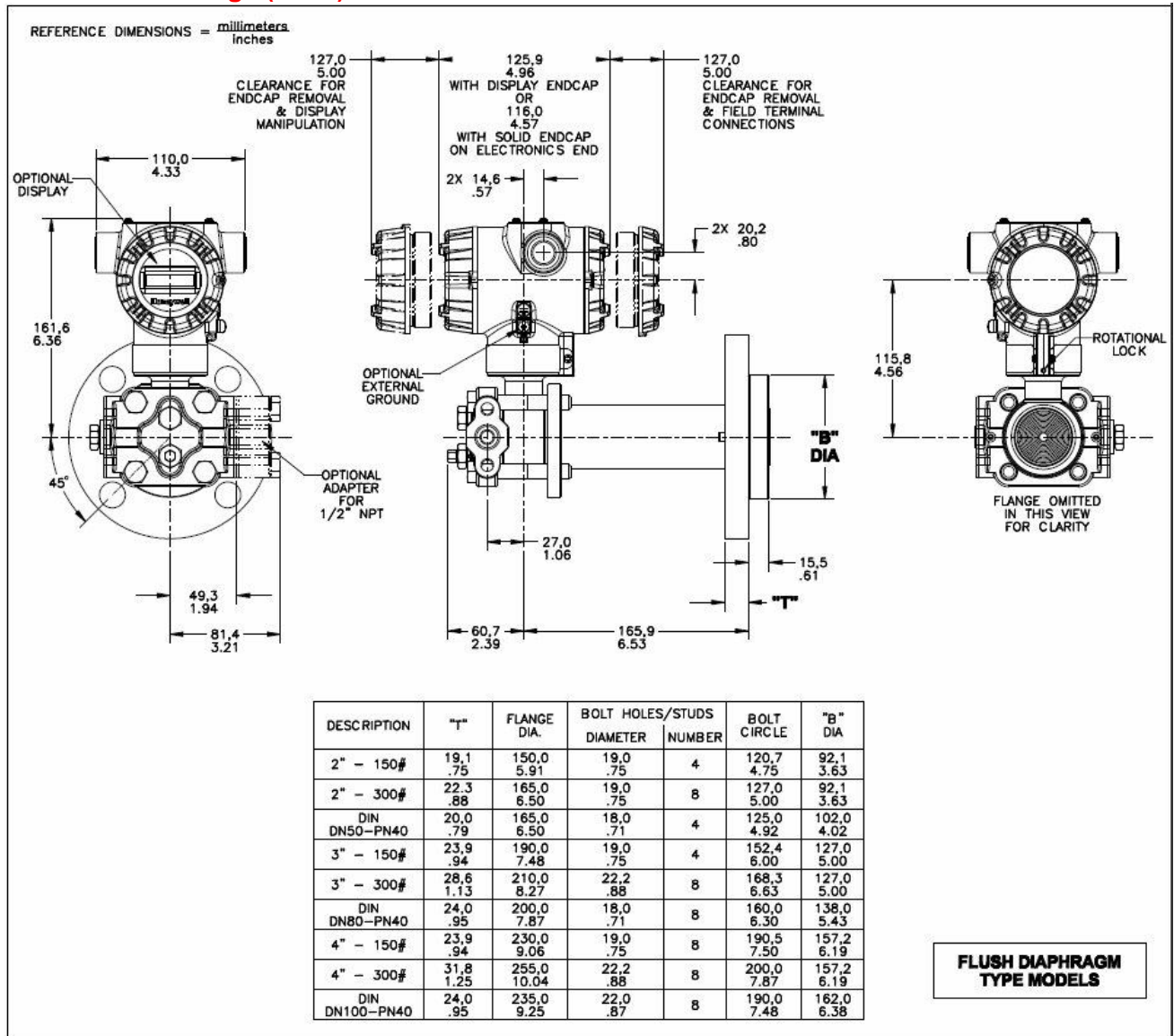

Figure 4 – Typical mounting dimensions for flush diaphragm type models STF724 and STF732.

**Dimensional Drawings (con't)**

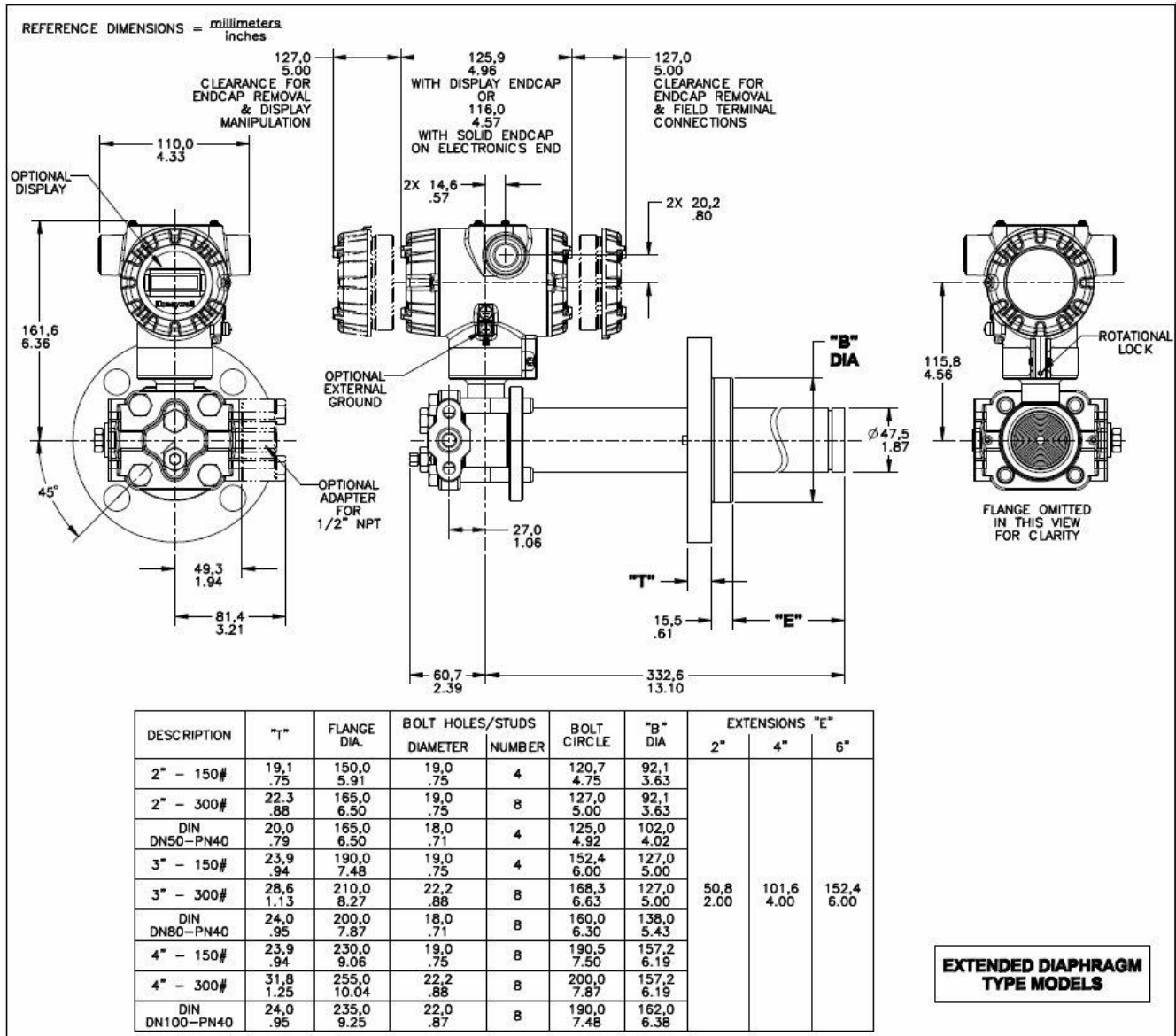

Figure 5 – Typical mounting dimensions for extended diaphragm type models STF724 and STF732.

**Dimensional Drawings (con't)**

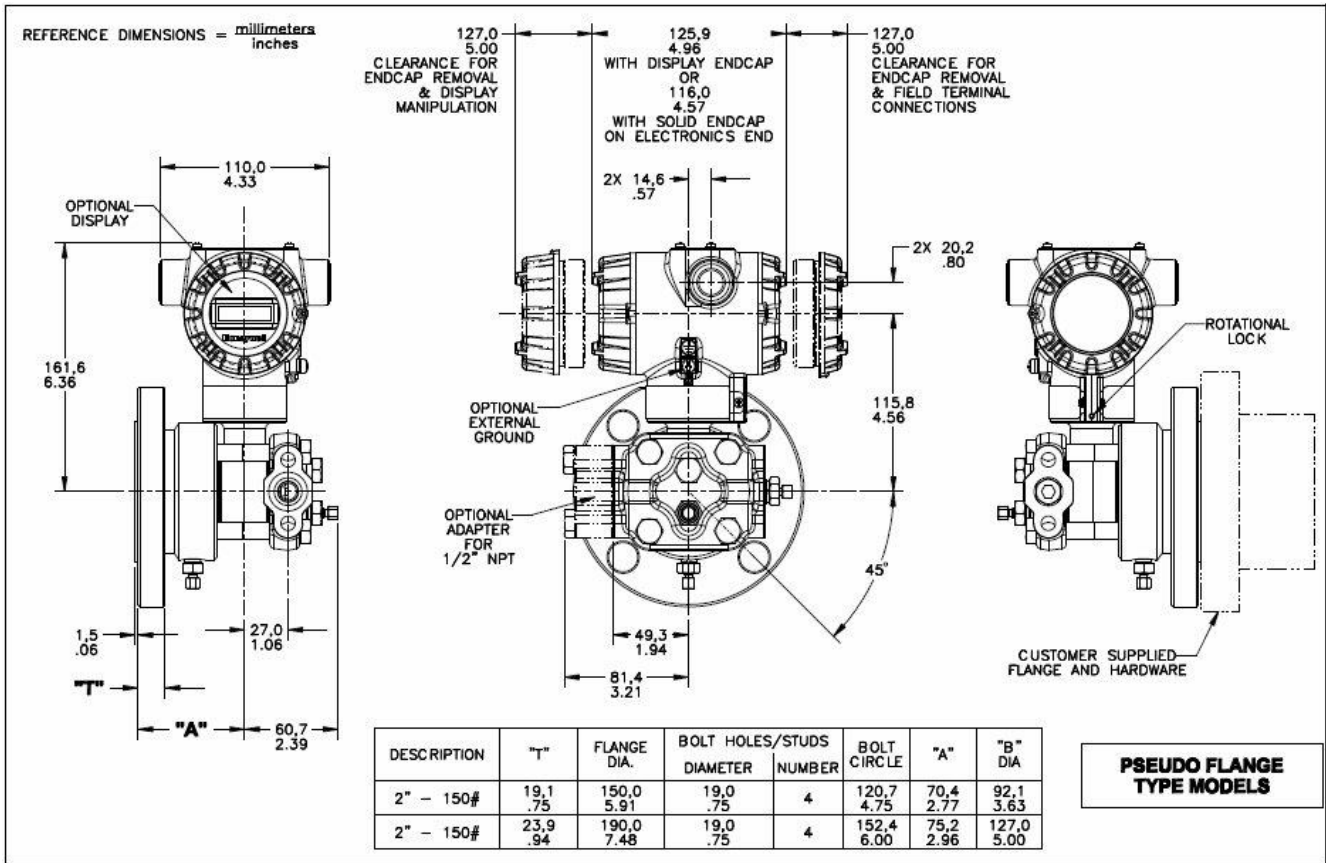

Figure 6 – Typical mounting dimensions for pseudo flange type models STF72F, STF73F, and STF74F.

Model Selection Guides are subject to change and are inserted into the specifications as guidance only. Prior to specifying or ordering a model check for the latest revision Model Selection Guides which are published at: [www.honeywellprocess.com/en-US/pages/default.aspx](http://www.honeywellprocess.com/en-US/pages/default.aspx)

**Model Selection Guide**

# Model STF700 Flange Mounted Liquid Level Transmitter

Model Selection Guide  
34-ST-16-103 Issue 12

Instructions									
<ul style="list-style-type: none"> <li>Select the desired Key Number. The arrow to the right marks the selection available.</li> <li>Make one selection from each Table (I, II and IX) using the column below the proper arrow.</li> <li>A(●) denotes unrestricted availability. Aletter denotes restricted availability.</li> <li>Restrictions follow Table IX.</li> </ul>									
Key Number	I	II	III	IV	V	VI	VII	VIII	IX
STF7 ___	- [ ] -	- [ ] -	- [ ] -	- [ ] -	- [ ] -	- [ ] -	- [ ] -	- [ ] -	+ [ ] [ ] [ ] [ ]

KEY NUMBER	URL	LRL	Max Span	Min Span	Units	Selection	Availability
Measurement Range Std Accuracy	400 (1000)	-400 (-1000)	400 (1000)	4 (10)	" H <sub>2</sub> O (mbar)	STF724	↓
	100 (7)	-100 (-7)	100 (7)	1 (0.07)	psi (bar)	STF732	↓
Accuracy	400 (1000)	-400 (-1000)	400 (1000)	1 (2.5)	" H <sub>2</sub> O (mbar)	STF72F	↓
	100 (7)	-100 (-7)	100 (7)	1 (0.07)	psi (bar)	STF73F	↓

TABLE I												
Meter Body & Flange Design	Materials of Construction		Design	Ref. Head	Vent Drain Valve on Ref. Head <sup>2</sup>	Barrier Diaphragm. (wetted)	Diaphragm. Plate (wetted)	Extension (wetted)	Sel.			
	a. Process Wetted Heads & Diaphragm Materials	Flush	Carbon <sup>1</sup> Steel	316 SS	316 SS	316L SS Hast C <sup>3</sup> Hast C <sup>3</sup>	316L SS 316L SS Hast C <sup>3</sup>	N/A	N/A	A _ _ _ _	•	•
W _ _ _ _										•	•	
B _ _ _ _										•	•	
Extended			Carbon <sup>1</sup> Steel	316 SS	316 SS	316L SS Hast C <sup>3</sup> Hast C <sup>3</sup>	316L SS 316L SS Hast C <sup>3</sup>	316L SS	316L SS	E _ _ _ _	•	•
										X _ _ _ _	•	•
										F _ _ _ _	•	•
Pseudo Flange		Carbon <sup>1</sup> Steel	316 SS	316 SS	316L SS Hast C <sup>3</sup> Hast C <sup>3</sup>	316L SS Hast C <sup>3</sup> Hast C <sup>3</sup>	N/A	N/A	J _ _ _ _	•	•	
									M _ _ _ _	•	•	
									N _ _ _ _	•	•	
b. Fill Fluid (Meter Body & Flange)						Silicone Oil 200				_ 1 _ _ _ _	•	•
						Fluorinated Oil CTFE				_ 2 _ _ _ _	•	•
						Silicone Oil 704				_ 3 _ _ _ _	•	•
					NEOBEE® M-20				_ 4 _ _ _ _	•	•	
c. Process Connection					Reference Head		Range		Sel.			
			1/4 NPT				High Pressure Side		_ A _ _ _ _	•	•	
			1/2 NPT Adapter - material matches head material and head bolt material <sup>11</sup>				Low Pressure Side		_ C _ _ _ _	•	•	
d. Bolts for Process Heads									_ H _ _ _ _	•	•	
									_ K _ _ _ _	•	•	
			Carbon Steel Bolts						_ _ _ C _ _	•	•	
			316 SS Bolts						_ _ _ S _ _	•	•	
e. Vent/Drain Type/Location					A286 SS (NACE) Bolts				_ _ _ N _ _	•	•	
					B7M Bolts				_ _ _ B _ _	•	•	
	Ref. Head Type	Vent Type	Location	Vent Material				Sel.				
	Single Ended	None	None	None				_ _ _ _ 1 _		•	•	
	Single Ended	Std	Side	Matches Head Material <sup>11</sup>				_ _ _ _ 2 _		•	•	
Single Ended	Ctr	Side	Stainless Steel Only				_ _ _ _ 3 _		t	t		
Dual Ended	Std	End	Matches Head Material <sup>11</sup>				_ _ _ _ 4 _		•	•		
Dual Ended	Cntr	End	Stainless Steel Only				_ _ _ _ 5 _		t	t		
Dual Ended	Vent/Plug	Side/End	Matches Head Material <sup>11</sup>				_ _ _ _ 6 _		•	•		
f. Gasket Material					Teflon® or PTFE (Glass Filled)				_ _ _ _ A	•	•	
					Viton® or Fluorocarbon Elastomer				_ _ _ _ B	•	•	

<sup>1</sup> Carbon Steel heads are zinc-plated and not recommended for water service due to hydrogen migration. For that service, use the 316 stainless steel Wetted Reference Head.  
<sup>2</sup> Vent/Drains are Teflon or PTFE coated for lubricity.  
<sup>3</sup> Hastelloy® C-276 or UNS N10276  
<sup>4</sup> Supplied as 316 SS or as Grade CF8M, the casting equivalent of 316 SS.  
<sup>5</sup> Supplied as indicated or as Grade CW12MW, the casting equivalent of Hastelloy® C-276  
<sup>11</sup> Except Carbon Steel Heads shall use 316SS Vent/Drain, Plugs & Adapters when required

Availability

STF7xx

TABLE II		Flange Material	Threaded Nut Ring Material	Selection	24 32	2F 3F		
Flange Assembly	a. Flange  (ANSI Flanges have 125-500 AARH Surface Finish)	3" ANSI Class 150 3" ANSI Class 300 DN80-PN40 DIN 4" ANSI Class 150 4" ANSI Class 300 DN100-PN40 DIN 2" ANSI Class 150 2" ANSI Class 300 DN50-PN40 DIN	Carbon Steel (non-wetted)	Carbon Steel (non-wetted)	1 __ 2 __ 3 __ 4 __ 5 __ 6 __ 7 __ 8 __ 9 __	• • • • • • • • •		
		3" ANSI Class 150 3" ANSI Class 300 DN80-PN40 DIN 4" ANSI Class 150 4" ANSI Class 300 DN100-PN40 DIN 2" ANSI Class 150 2" ANSI Class 300 DN50-PN40 DIN	304 SS (non-wetted)	304 SS (non-wetted)	A __ B __ C __ D __ E __ F __ Q __ U __ V __	• • • • • • • • •		
		3" ANSI Class 150 3" ANSI Class 300 DN80-PN40 DIN 4" ANSI Class 150 4" ANSI Class 300 DN100-PN40 DIN 2" ANSI Class 150 2" ANSI Class 300 DN50-PN40 DIN	316 SS (non-wetted)	304 SS (non-wetted)	H __ J __ K __ L __ M __ N __ W __ X __ Z __	• • • • • • • • •		
		<b>Pseudo Flange on Standard DP</b>				<b>Sel.</b>		
		2" ANSI Class 150 without Vent/Drain	316L SS (wetted)	Not Applicable	S __		•	
		2" ANSI Class 150 with Vent/Drain			T __		•	
		3" ANSI Class 150 without Vent/Drain			P __		•	
		3" ANSI Class 150 with Vent/Drain			R __		•	
		b. Gasket Ring (wetted)	No Selection		_ 0 _		•	
			Flush Design	316L SS Hastelloy® C <sup>3</sup>	_ 1 _ _ 2 _	s s		
			Extended Design	316L SS	_ 5 _	v		
		c. Extension (wetted)	No Selection		_ _ 0		•	
			Flush		_ _ F	w		
			<b>Diameter</b>	<b>Length</b>	<b>Sel.</b>			
			1.87 Inches (for 2", 3" or 4" spud) <sup>13</sup>	2 inches 4 inches 6 inches	_ _ C _ _ D _ _ E	v v v		

<sup>3</sup> Hastelloy® C-276 or UNS N10276

<sup>13</sup> For part numbers and pricing information on Tank Spuds refer to page ST-91 (Supplementary Accessories & Kits).

TABLE III		Agency Approvals (see data sheet for Approval Code Details)	Selection		
Approvals	No Approvals Required		0	*	*
	FM Explosion proof, Intrinsically Safe, Non-incendive, & Dustproof		A	*	*
	CSA Explosion proof, Intrinsically Safe, Non-incendive, & Dustproof		B	*	*
	ATEX Explosion proof, Intrinsically Safe & Non-incendive		C	*	*
	IECEX Explosion proof, Intrinsically Safe & Non-incendive		D	*	*
	SAEx/CCoE Explosion proof, Intrinsically Safe & Non-incendive		E	*	*
	INMETRO Explosion proof, Intrinsically Safe & Non-incendive		F	*	*
	NEPSI Explosion proof, Intrinsically Safe & Non-incendive		G	*	*



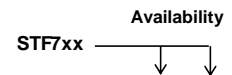

TABLE IV TRANSMITTER ELECTRONICS SELECTIONS				Selection	24 32	2F 3F
<b>a. Electronic Housing Material &amp; Connection Type</b>	Material	Connection	Lightning Protection			
	Polyester Powder Coated Aluminum	1/2 NPT	None	A __	*	*
	Polyester Powder Coated Aluminum	M20	None	B __	*	*
	Polyester Powder Coated Aluminum	1/2 NPT	Yes	C __	*	*
	Polyester Powder Coated Aluminum	M20	Yes	D __	*	*
	316 Stainless Steel (Grade CF8M)	1/2 NPT	None	E __	*	*
	316 Stainless Steel (Grade CF8M)	M20	None	F __	*	*
	316 Stainless Steel (Grade CF8M)	1/2 NPT	Yes	G __	*	*
316 Stainless Steel (Grade CF8M)	M20	Yes	H __	*	*	
<b>b. Output/ Protocol</b>	Analog Output		Digital Protocol			
	4-20mA dc		HART Protocol	_ H _	*	*
	4-20mA dc none		DE Protocol Foundation Fieldbus	_ D _ _ F _	* *	* *
<b>c. Customer Interface Selections</b>	Indicator	Ext Zero, Span & Config Buttons	Languages			
	None	None	None	_ _ 0	*	*
	None	Yes (Zero/Span Only)	None	_ _ A	f	f
	Basic	None	English	_ _ B	*	*
	Basic	Yes	English	_ _ C	*	*
	Simple (w/internal Zero, Span & Conf Buttons)	None	English	_ _ D	u	u

TABLE V CONFIGURATION SELECTIONS				Selection		
<b>a. Application Software</b>	Diagnostics					
	Standard Diagnostics			1 _ _	*	*
<b>b. Output Limit, Failsafe &amp; Write Protect Settings</b>	Write Protect	Fail Mode	High & Low Output Limits <sup>3</sup>			
	Disabled	High > 21.0mAdc	Honeywell Std (3.8 - 20.8 mAdc)	_ 1 _	f	f
	Disabled	Low < 3.6mAdc	Honeywell Std (3.8 - 20.8 mAdc)	_ 2 _	f	f
	Enabled	High > 21.0mAdc	Honeywell Std (3.8 - 20.8 mAdc)	_ 3 _	f	f
	Enabled	Low < 3.6mAdc	Honeywell Std (3.8 - 20.8 mAdc)	_ 4 _	f	f
	Enabled	N/A	N/A Fieldbus	_ 5 _	g	g
	Disabled	N/A	N/A Fieldbus	_ 6 _	g	g
<b>c. General Configuration</b>	Factory Standard			_ _ S	*	*
	Custom Configuration (Unit Data Required from customer)			_ _ C	*	*

<sup>3</sup> NAMUR Output Limits 3.8 - 20.5mAdc can be configured by the customer or select custom configuration Table Vc

TABLE VI CALIBRATION & ACCURACY SELECTIONS				Selection		
<b>Accuracy and Calibration</b>	Accuracy	Calibrated Range	Calibration Qty			
	Standard	Factory Std	Single Calibration	A	*	*
	Standard	Custom (Unit Data Required)	Single Calibration	B	*	*

TABLE VII ACCESSORY SELECTIONS				Selection		
<b>a. Mounting Bracket</b>	None (not required with flange mount unit)			0 _ _ _	*	*
<b>b. Customer Tag</b>	No customer tag			_ 0 _ _	*	*
	One Wired Stainless Steel Tag (Up to 4 lines 26 char/line)			_ 1 _ _	*	*
	Two Wired Stainless Steel Tag (Up to 4 lines 26 char/line)			_ 2 _ _	*	*
<b>c. Unassembled Conduit Plugs &amp; Adapters</b>	No Conduit Plugs or Adapters Required			_ _ A0	*	*
	1/2 NPT Male to 3/4 NPT Female 316 SS Certified Conduit Adapter			_ _ A2	n	n
	1/2 NPT 316 SS Certified Conduit Plug			_ _ A6	n	n
	M20 316 SS Certified Conduit Plug			_ _ A7	m	m
	Minifast <sup>®</sup> 4 pin (1/2 NPT)			_ _ A8	n	n
	Minifast <sup>®</sup> 4 pin (M20)			_ _ A9	m	m

TABLE VIII	OTHER Certifications & Options: (String in sequence comma delimited (XX, XX, XX,....))	Selection		
Certifications & Warranty	None - No additional options	00	*	*
	NACE MR0175; MR0103; ISO15156 (FC33338) Process wetted parts only	FG	*	*
	NACE MR0175; MR0103; ISO15156 (FC33339) Process wetted and non-wetted parts	F7	c	c
	Marine (DNV, ABS, BV, KR, LR)	MT	i	i
	EN10204 Type 3.1 Material Traceability (FC33341)	FX	*	*
	Certificate of Conformance (F3391)	F3	*	*
	Calibration Test Report & Certificate of Conformance (F3399)	F1	*	*
	Certificate of Origin (F0195)	F5	*	*
	FMEDA (SIL 2/3) Certification (FC33337)	FE	j	j
	Over-Pressure Leak Test Certificate (1.5X MAWP) (F3392)	TP	*	*
	Cert Clean for O <sub>2</sub> or CL <sub>2</sub> service per ASTM G93	OX	e	e
PMI Certification	PM	*	*	

TABLE IX	Manufacturing Specials			
Factory	Factory Identification	0000	*	*

MODEL RESTRICTIONS

Restriction Letter	Available Only with		Not Available with	
	Table	Selection(s)	Table	Selection(s)
a			VIII	FG, F7
b	Select only one option from this group			
c	Id	___N,B___		
e	lb	_2_____		
f			IVb	_F_
g			IVb	_H,D_
i	IVa	C,D,G,H__		
j	IVb	_H_	Vb	_1,2,5,6,_
m	IVa	B,D,F,H__		
n	IVa	A,C,E,G__		
s	la	A,W,B,E,X,F,J_____		
t			la	J_____
u	IVb	_H_		
v	la	M,N,R,S_____		
w			la	M,N,R,S_____
			llb	_5_

## Sales and Service

For application assistance, current specifications, pricing, or name of the nearest Authorized Distributor, contact one of the offices below.

### ASIA PACIFIC

Honeywell Process Solutions,  
(TAC) [hfs-tac-support@honeywell.com](mailto:hfs-tac-support@honeywell.com)

#### Australia

Honeywell Limited  
Phone: +(61) 7-3846 1255  
FAX: +(61) 7-3840 6481  
Toll Free 1300-36-39-36  
Toll Free Fax:  
1300-36-04-70

#### China – PRC - Shanghai

Honeywell China Inc.  
Phone: (86-21) 5257-4568  
Fax: (86-21) 6237-2826

#### Singapore

Honeywell Pte Ltd.  
Phone: +(65) 6580 3278  
Fax: +(65) 6445-3033

#### South Korea

Honeywell Korea Co Ltd  
Phone: +(822) 799 6114  
Fax: +(822) 792 9015

### EMEA

Honeywell Process Solutions,  
Phone: + 80012026455 or  
+44 (0)1344 656000

Email: (Sales)

[FP-Sales-Apps@Honeywell.com](mailto:FP-Sales-Apps@Honeywell.com)

or

(TAC)

[hfs-tac-support@honeywell.com](mailto:hfs-tac-support@honeywell.com)

### AMERICA'S

Honeywell Process Solutions,  
Phone: (TAC) 1-800-423-9883 or  
215/641-3610  
(Sales) 1-800-343-0228

Email: (Sales)

[FP-Sales-Apps@Honeywell.com](mailto:FP-Sales-Apps@Honeywell.com)

or

(TAC)

[hfs-tac-support@honeywell.com](mailto:hfs-tac-support@honeywell.com)

*Specifications are subject to change without notice.*

**For more information**

To learn more about SmartLine Pressure Transmitters visit [www.honeywellprocess.com](http://www.honeywellprocess.com)  
Or contact your Honeywell Account Manager

**Process Solutions**

Honeywell  
1250 W Sam Houston Pkwy S  
Houston, TX 77042

Honeywell Control Systems Ltd  
Honeywell House, Skimped Hill Lane  
Bracknell, England, RG12 1EB

Shanghai City Centre, 100 Jungi Road  
Shanghai, China 20061

[www.honeywellprocess.com](http://www.honeywellprocess.com)

34-ST-03-103  
February 2018

©2018 Honeywell International Inc.

**Honeywell**